

AEBus Technical Reference Manual

REV.	REVISION DATE	DCO #	DESCRIPTION OF CHANGE
A	2022-05-27	DCO-000143	Initial Release of Technical Reference Manual
B	2023-03-07	DCO-000198	AEBus Version 3 updates
C	2023-10-23	DCO-000255	Corporate identity updated.
D	2023-11-20	DCO-000267	Added functions (PGN 61705 HVESSTS1, PGN 64538 HVESSTC1, PGN 126982 Batt Stats Reduced, and PGN 126983 Fault Status Reduced)
E	2024-08-01	DCR-24-0064	Minor update to 3.5 AEBus Configuration

DISCOVER ENERGY SYSTEMS CORP.

320 - 13711 International Place
Richmond, BC, V6V 2Z8, Canada
www.discoverlithium.com

Proprietary: This document is the property of Discover Energy Systems Corp. Duplication of this document in whole or in part for any purposes other than those for which it was originally intended, without the written approval of Discover Energy Systems Corp or their agents, is strictly prohibited.

LICENSE AGREEMENT

Important Notices and Disclaimers Concerning Discover Energy Systems Corp.'s ("Discover") AEBus Protocol Specification Document ("Document"). The Document is made available for use subject to important notices and legal disclaimers.

Notice and Disclaimer of Liability Concerning the Use of the Document

The Document and contents herein are licensed, not sold.

GRANT OF LICENSE. Subject to the terms of this Agreement, Discover hereby grants Licensee a limited, nonexclusive, non-transferable, royalty free license (without the right to sublicense) to use the Document solely for the purpose of Licensee's internal development efforts to develop applications to work in conjunction with Discover products referenced in the Document and for which the Document was provided. Licensee shall have no right to distribute, license (whether or not through multiple tiers) or otherwise transfer the Document to any third party or incorporate the Document in any software, product, or technology.

Use or practice of the contents of this Document is wholly voluntary. Discover disclaims liability for any personal injury, property or other damage, of any nature whatsoever, whether special, indirect, consequential, or compensatory, directly or indirectly resulting from the publication, use of, or reliance upon the Document.

NO WARRANTIES. Discover expressly disclaims any warranty for the use or practice of the contents of this Document. The Document is provided "as is" without warranty of any kind, either express or implied, including, without limitation, the implied warranties or merchantability, fitness for a particular purpose, or infringement. The entire risk arising out of use or performance of the Document remains with you.

NO LIABILITY FOR CONSEQUENTIAL DAMAGES. In no event shall Discover or its suppliers be liable for any damages whatsoever (including, without limitation, damages for loss of business profits, business interruption, loss of business

DISCOVER ENERGY SYSTEMS

information, or any other pecuniary loss) arising out of the use of or inability to use this Document, even if Discover has been advised of the possibility of such damages.

NO DUTY FOR SERVICE. In publishing and making the Document available, Discover is not suggesting or rendering professional or other services for, or on behalf of, any person or entity. Nor is Discover undertaking to perform any duty owed by any other person or entity to another. Nothing herein shall be construed to require Discover to provide support services or updates, upgrades, bug fixes or modifications to the use or content of the Document. Any person utilizing the Document, should rely upon his or her own independent judgment in the exercise of reasonable care in any given circumstance.

BY THE USE OR PRACTICE OF THE CONTENTS HEREIN, YOU ACKNOWLEDGE THAT YOU HAVE READ, UNDERSTAND AND AGREE TO BE BOUND BY THE TERMS AND CONDITIONS INDICATED ABOVE.



320 - 13711 International Place, Richmond, BC, V6V 2Z8, Canada

discoverlithium.com



+ 1.604.242.0350



info@discoverlithium.com

1.Introduction	4
1.1 Purpose.....	4
1.2 Scope.....	4
1.3 Audience.....	4
2.Reference	4
2.1 Terms and Definitions.....	5
2.2 Notation.....	5
3.Overview	5
3.1 AEBus Overview.....	5
3.2 J1939 Overview	6
3.3 N2K Overview.....	7
3.4 Network Management.....	8
3.5 AEBus Configuration.....	9
4.AEBus Node Connection Procedure	9
5.AEBus Control of Charging Sources	9
5.1 Master Nodes.....	9
5.2 Routing Nodes.....	9
5.3 Uncontrolled Charging Sources.....	10
6.AEBus PGN Listing	10
6.1 PGN 65792 (0x010100) – Device Info (DevInfo).....	10
6.2 PGN 66048 (0x010200) – Product Info (ProdInfo).....	12
6.3 PGN 77824 (0x013000) –Time Stamp (TimeStamp).....	13
6.4 PGN 82944 (0x014400) – Identify.....	13
6.5 PGN 126977 (0x01F001) – Battery Stats (BattSts).....	14
6.6 PGN 126978 (0x01F002) – Datalog Status (DatalogSts).....	15
6.7 PGN 126979 (0x01F003) – Fault Status (FaultSts).....	16
6.8 PGN 126980 (0x01F004) – Shutdown Info (ShutdownInfoData).....	17
6.9 PGN 126981 (0x01F005) – Heartbeat.....	18
6.10 PGN 126982 (0x01F006) – Battery Stats Reduced (BattStsRed).....	19
6.11 PGN 126983 (0x01F007) – Fault Status Reduced (FaultStsRed).....	20
7.J1939 PGN Listings	21
7.1 PGN 59392 (0xE800) – ISO Acknowledgment (ISOAck).....	21
7.2 PGN 59904 (0xEA00) – ISO Request (ISORqst).....	21
7.3 PGN 60928 (0xEE00) – ISO Address Claim.....	22
7.4 PGN 61588 (0x00F094) – HVES1D5.....	22
7.5 PGN 61600 (0x00F0A0) – HVES1D7.....	23
7.6 PGN 64789 (0x00FD15) – BCH1.....	24
7.7 PGN 6912 (0x001B00) – HVES1C1.....	25
7.8 PGN 61705 (0x00F109) – HVESSTS1.....	26
7.9 PGN 64538 (0x00FC1A) – HVESSTC1.....	27



1. Introduction

1.1 Purpose

This document presents a technical reference manual for quick integration with AEBus enabled batteries and accessories. This is not a comprehensive protocol document and some Proprietary PGNs have been omitted.

1.2 Scope

This document specifies the AEBus interface of AES batteries and accessories. It should be noted that some models of Discover AES batteries are equipped with 2 physical CAN networks, care should be taken to ensure that the correct network is being interfaced with. This document will define the protocol, signals and functionality that can be achieved through integration with AEBus enabled devices.

1.3 Audience

This document is intended for the use of engineers both internal and external to Discover Energy Corp. who intend to interface with Discover products through the AEBus protocol. It is expected that the audience has a working knowledge of the CAN physical layer as well as the J1939 and NMEA2000 standards for communication.

2. Reference

Voss, Wilfried. A Comprehensive Guide to J1939. Copperhill Media Corporation, 2008.

800-0003	AEBus Protocol Manual
805-0001	14-24-2800 12-36-6700 12-48-6650 Operating Manual
805-0015	44-24-2800 42-48-6650 Operating Manual For Solar Applications
805-0022	14-12-3000 14-24-3000 14-36-3000 14-48-3000 Operating Manual
805-0025	44-48-3000 Operating Manual
805-0027	AES Professional Installation and Operation Manual
805-0037	Helios ESS Installation and Operation Manual
805-0043	AES RACKMOUNT Installation and Operation Manual
805-0033	LYNK II Installation and Operation Manual
805-0035	LYNK LITE Installation and Operation Manual



2.1 Terms and Definitions

AES	Advanced Energy Systems
BMS	Battery Management System
CAN	Controller Area Network
LSB	Least Significant Bit
MSB	Most Significant Bit
RSVD	Reserved for Future Use
PDU	Protocol Data Unit
PGN	Parameter Group Number
FRAME	A Single 8 Byte CAN Frame
MESSAGE	One or more frames comprising a complete set of data
FIELD	A single parameter within a message

2.2 Notation

FORMAT	MEANING
0x	Hexadecimal (base 16) values are prefixed with "0x"
0b	Binary (base 2) values are prefixed with "0b"
&	Bitwise AND operation

MSB							LSB
bit7	bit6	bit5	bit4	bit3	bit2	bit1	bit0

3. Overview

3.1 AEBus Overview

The purpose of the AEBus network is to allow real-time Discover AES battery and accessory information to be displayed, collected, and exchanged between batteries, accessories and third party nodes. The network protocol runs over J1939 at 250 kBaud and uses NMEA 2000 fast packets as its transport layer. All AEBus nodes are auto-addressed so all nodes on the network that require active involvement in communications must support ISO address claims (PGN: 0xEE00).

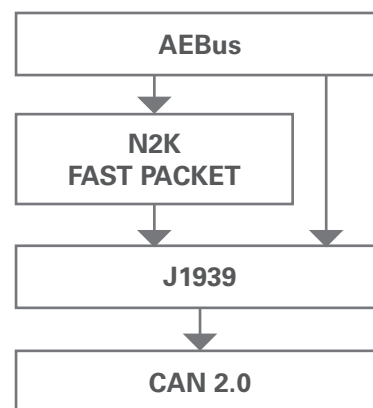

The AEBus device model is a peer-to-peer network during normal operations, and a client server network when a file transfer is underway. Any device can send a message of any type during normal operation, this rule will be limited depending on the device host implementation but the protocol itself does not put any restrictions on a node.

Newly connected AEBus nodes wishing to actively participate on the network must establish a connection to other nodes already on the bus. A node connects to the bus and requests information about operational parameters of all nodes, by issuing an ISO Request for the Device Info PGN. Nodes already on the bus request the same information from newly connected nodes.

A node joins initially as a device. The devices will provide information about its firmware version and device type. It also provides information about the AEBus version that it supports. This information is stored by all devices on the bus so that they can selectively manage how they interact with the device.

Control of charge sources can be achieved by AEBus nodes that have charger control enabled in their host implementation. The control of these devices is described in AEBus Control of Charging Sources.

In addition, AEBus allows for devices on the network to transfer files. This protocol can be used to transfer Firmware Upgrades, debug files, or other transfers incorporated into the host implantation. There is no special restriction on which devices can initiate a file transfer from any other device in the network. The file transfer process is described in AEBus Firmware Update Procedure.

3.2 J1939 Overview

J1939 is a high-layer protocol based on CAN. It provides serial data communication between embedded systems. The particular characteristics of J1939 are:

- Extended CAN identifier (29 bit)
- Baud rate of 250.0 kbit/s
- Peer-to-peer and broadcast communication
- Network management

Refer to the SAE J1939 standard for more details.

Table 31 - J1939 PGN Fields Reference

CAN ID					
29 bit					
Priority	PGN			Source Address	
3 bit	18 bit			8 bit	
	Extended Data Page	Data Page	PDU Format		PDU Specific
	1 bit	1 bit	8 bit		8 bit

If PDU Format is 0 – 239 (0x00 – 0xEF) then the PDU specific field is a destination address. If PDU Format is 240 – 255 (0xF0 – 0xFF) then the PDU Specific field is a group extension and the frame is a broadcast.



3.2.1 Example ID Frame Decomposition with Battery Stats PGN

29 bit CAN ID	0x19F0010E
Source Address	0x19F0010E & 0x000000FF = 0x0E
18 bit PGN	0x19F001 & 0x1FFFF = 0x1F001
3 bit Priority	(0x19F001 & 0x380000) >> 18 = 6

3.3 N2K Overview

AEBus adds the Fast Packet N2K extension to J1939 which allows the transmission of messages larger than a single 8 byte J1939 frame. The first frame includes a frame number, sequence number and a packet size. Following frames include only the sequence number and frame number.

The following table shows the composition of a single message.

PACKET NUMBER	DATA 0		DATA 1	DATA 2 – 7
1	3 bit Sequence	5 bit frame number	Packet Size	Data
2 – N	3 bit Sequence	5 bit frame number	Data	Data

For example a 16 byte packet is sent as the following 3 J1939 frames. The sequence ID is randomly generated, in the example below A is used.

SEQUENCE	FRAME	DATA							
A	0	0xA0	0x0F	0x01	0x02	0x03	0x04	0x05	0x06
A	1	0xA1	0x07	0x08	0x09	0x0A	0x0B	0x0C	0x0D
A	2	0xA2	0x0E	0x0F	0x10	0xFF	0xFF	0xFF	0xFF

3.3.1 Example N2K Fast Packet Decomposition with Battery Stats PGN 126977 (0x01F001)

FRAME	ID	DATA							
0	0x19F0010E	0x80	0x2C	0x00	0x00	0x00	0x00	0x15	0x1F
1	0x19F0010E	0x81	0x02	0x64	0xE1	0x0B	0xDC	0x0B	0xE1
2	0x19F0010E	0x82	0x0B	0xD9	0x0B	0xD5	0x0B	0xE7	0x0B
3	0x19F0010E	0x83	0x9F	0x0B	0xCD	0x0B	0xE5	0x0B	0xE3
4	0x19F0010E	0x84	0x0B	0xF2	0x0B	0xD9	0x0B	0xC6	0x0B
5	0x19F0010E	0x85	0xD4	0x0B	0xF1	0x0B	0xD9	0x0B	0x92
6	0x19F0010E	0x86	0xBD	0x00	0x00	0xFF	0xFF	0xFF	0xFF

19F001	PGN 0x1F001, BatStats
0E	Source ID
0x80, 0x81, 0x82, 0x83, 0x84, 0x85, 0x86,	The first data byte includes the 3 bit sequence ID and frame number
0x2C	The second byte of the first frame is the total data length of the fast packet, in this case 44 data bytes.
0x00 0x00 0x00 0x00	Battery current, uint32. 0 mA in this example
0x15	Cell block temperature, int8. 21 degC in this example
0x1F	BMS temperature, int8. 31 degC in this example
0x02	State of Charge uint8. 2% in this example
0x64	State of Health uint8. 100% in this example
0xE1 0x0B....0xD9 0x0B	Cell Module Voltage, uint16. 3041mV 3033 mV
0x92 0xBD 0x00 0x00	Terminal Voltage, uint32. 48,530 mV

3.4 Network Management

When a node claims an address, it sends PGN 0x00EE00 with the desired sourced address as well as the 64 bit device name.

Device name data includes information about the device and its main function.

IDENTITY NUMBER	MANUFACTURER CODE	ECU INSTANCE	FUNCTION INSTANCE	FUNCTION	RSVD	VEHICLE SYSTEM	VEHICLE INSTANCE	INDUSTRY GROUP	ARBITRARY ADDRESS CAPABLE
21 bit	11 bit	3 bit	5 bit	8 bit	1 bit	7 bit	4 bit	3 bit	1 bit

AEBus nodes will adhere to the device name values listed below:

Unique Identifier	Serial Number & 0x1FFFFFF
Manufacturing Code	932
ECU Instance (lower)	0
Function Instance (upper)	0
Device Function	4 = Battery Monitor (BMS) 28 = Gateway (LYNK) 60 = Display (Type-A/B BDI) 141 = Battery Charger
RSVD	RSVD
Vehicle System	0 (Non Specific)
Vehicle Instance	0
Industry Group	0 (Global Industry Group)
Self-Configurable Address	1 (Arbitrary Address Capable)

3.5 AEBus Configuration

Bit-Rate	250 kbps
Dynamic Node Address Range	128-253 <ul style="list-style-type: none"> • 254 – Null Address • 255 – Broadcast Address
Manufacturer	Discover Battery
Manufacturer ID	932

3.5.1 Static Source Address

Version Added	3
---------------	---

Source addresses can be assigned for range 1-253 excluding 73. If a node fails to claim its static source address, it will default to dynamic address claiming an address in the range of 128-253.

4. AEBus Node Connection Procedure

Newly connected AEBus nodes wishing active participation on the network must establish a connection to other nodes already on the bus. A node claims a source address and then requests information about operational parameters of all other nodes, by issuing an ISO Request for the Device Info PGN. Nodes already on the bus request the same information from newly connected nodes.

A node joins initially as a device. The devices will provide information about its firmware version and device type. It also provides information about the AEBus version that it supports. This information is stored by all devices on the bus so that they can selectively manage how they interact with the device.

5. AEBus Control of Charging Sources

AEBus batteries can control J1939 compatible battery charging sources through the HVES1D5, HVES1D7 and BCH1 messages. Control of non-J1939 compatible charging sources may be done via third-party protocols.

5.1 Master Nodes

If multiple AEBus batteries are on the same AEBus network then one battery is elected to be the master node. The AEBus master node is determined by using the lowest J1939 source address of all nodes. A master node maintains exclusive control of the AEBus connected chargers and transmits HVES1D5 and HVES1D7 pgn's using aggregate AEBus battery data.

5.2 Routing Nodes

A routing node has a separate, third-party protocol, connection to one or more charging sources. The routing node may assume it has exclusive control of these sources if the third-party protocol allows it. AEBus may have multiple routing nodes controlling separate networks of charging sources.



5.3 Uncontrolled Charging Sources

Charging sources not connected to a master or routing node are considered uncontrolled and should implement the recommended “open loop” charging protocol.

6. AEBus PGN Listing

6.1 PGN 65792 (0x010100) – Device Info (DevInfo)

Message Type	N2K Fast Packet
Transmission Rate	Request Only
Default Priority	6
Version Added	1

FIELD	FIELD LENGTH (BITS)	FIELD TYPE	FIELD DESCRIPTION
1	28	unsigned integer (M.mm.pp.tt)	Firmware Version 4 bit major version number 8 bit minor version number 8 bit patch version number 8 bit pre-release version number
2	4	unsigned integer	AEBus Protocol Version 0 = Protocol version 1 1 = Protocol version 2 2 = Protocol version 3 3 = Protocol version 4
3	8	Unsigned enum	NodeType 4 = Battery Monitor 28 = Gateway 60 = Display 141 = Battery Charger
4	64		Device Specific Information. For how to use this field, see “6.1.1 BMS Node Specific”, “6.1.2 LYNK Node Specific”, and “6.1.3 Type A/B BDI Node Specific”.

6.1.1 BMS Node Specific – Description of Field 4

FIELD	FIELD LENGTH (BITS)	FIELD TYPE	FIELD DESCRIPTION
1	16	unsigned integer (Ah)	Battery Capacity
2	8	unsigned integer	Module Count
3	8	unsigned enum	Module Type: 1 – LiFePO4
4	8	unsigned enum	Node Capability 0x01 = Acts as master 0x02 = Acts as router 0x04 = Acts as updater
5	16	unsigned integer (MM.mm)	Hardware version: 0-7 - Minor Version 8-15 - Major Version
6	8	RSVD	RSVD

6.1.2 LYNK Node Specific – Description of Field 4

FIELD	FIELD LENGTH (BITS)	FIELD TYPE	FIELD DESCRIPTION
1	16	unsigned integer (MM.mm)	Hardware version: 0-7 - Minor Version 8-15 - Major Version

6.1.3 Type A/B BDI Node Specific – Description of Field 4

FIELD	FIELD LENGTH (BITS)	FIELD TYPE	FIELD DESCRIPTION
1	16	unsigned integer (MM.mm)	Hardware version: 0-7 - Minor Version 8-15 - Major Version

6.2 PGN 66048 (0x010200) – Product Info (ProdInfo)

Message Type	N2K Fast Packet
Transmission Rate	Request Only
Default Priority	6
Version Added	2

FIELD	FIELD LENGTH (BITS)	FIELDTYPE	FIELD DESCRIPTION
1	32	unsigned integer (MM.mm.pp.tt)	Application FW Version 8 bit major version number 8 bit minor version number 8 bit patch version number 8 bit pre-release version number
2	32	unsigned integer (MM.mm.pp.tt)	Bootloader Version 8 bit major version number 8 bit minor version number 8 bit patch version number 8 bit pre-release version number All 0's if not supported
3	32	unsigned integer (MM.mm.pp.tt)	EEPROM Schema Version 8 bit major version number 8 bit minor version number 8 bit patch version number 8 bit pre-release version number All 0's if not supported
4	16	unsigned integer (MM.mm)	Hardware Version 8 bit major version number 8 bit minor version number
5	8	unsigned enum	NodeType 4 = Battery Monitor 28 = Gateway 60 = Display 141 = Battery Charger
6	192	string	Serial Number ASCII left aligned. Unused characters are populated with null characters.
7	320	string	Manufacturing Information ASCII left aligned. Unused characters are populated with null characters.

6.3 PGN 77824 (0x013000) – Time Stamp (TimeStamp)

Message Type	J1939
Transmission Rate	Request Only
Default Priority	6
Version Added	2

FIELD	FIELD LENGTH (BITS)	FIELD TYPE	FIELD DESCRIPTION
1	32	unsigned integer	Time in seconds since Jan 1, 1970 - Unix Epoch
2	32	unsigned integer	Fractional seconds $1/2^{32}$

6.4 PGN 82944 (0x014400) – Identify

Message Type	J1939
Transmission Rate	Asynchronous
Default Priority	5
Version Added	3

This PGN can be sent to a node that has control of a user interface LED. The receiving node will flash its user interface LED for the specified period of time. If no period of time was sent, the node defaults to flashing the LED for 60 seconds.

FIELD	FIELD LENGTH (BITS)	FIELD TYPE	FIELD DESCRIPTION
1	32	unsigned integer	Identify the period of time in number of seconds
2	32	RSVD	RSVD

6.5 PGN 126977 (0x01F001) – Battery Stats (BattSts)

Message Type	N2K Fast Packet
Transmission Rate	250 ms
Default Priority	6
Version Added	1

FIELD	FIELD LENGTH (BITS)	FIELD TYPE	FIELD DESCRIPTION
1	32	signed integer (mA)	Battery Current Charge current > 0 Discharge current < 0
2	8	signed integer (°C)	Battery Cell Block Temperature
3	8	signed integer (°C)	Battery Management System Temperature
4	8	unsigned integer (%)	State of Charge Valid range of 0-100%
5	8	unsigned integer (%)	State of Health Presently fixed value at 100%
6 – 21	16*16	unsigned integer (mV)	Cell Voltage (0xFFFF is Invalid or unpopulated module)
22	32	unsigned integer (mV)	Battery Terminal Voltage (0xFFFF is invalid)



6.6 PGN 126978 (0x01F002) – Datalog Status (DatalogSts)

Message Type	N2K Fast Packet
Transmission Rate	10000 ms
Default Priority	6
Version Added	1

FIELD	FIELD LENGTH (BITS)	FIELD TYPE	FIELD DESCRIPTION
1	32	unsigned integer (Wh)	Discharge Watt Hours Total accumulated energy discharged (in Watt-Hours) over lifetime of the battery.
2	32	unsigned integer (Wh)	Charge Watt Hours Total accumulated energy charged (in Watt-Hours) over lifetime of the battery.
3	32	unsigned integer (s)	Total Charge Time Total accumulated time over the lifetime of the battery, that the battery current has been > 200 mA (i.e. charging).
4	32	unsigned integer (s)	Total Idle Time Total accumulated time over the lifetime of the battery that the battery current has been between -200 mA and 200 mA (i.e. idle).
5	32	unsigned integer (s)	Total 0-10% Discharge Time Total accumulated time over the lifetime of the battery, that the battery discharge current has been > 200 mA and ≤ 10% of nominal current rating (1C).
6	32	unsigned integer (s)	Total 10-20% Discharge Time Total accumulated time over the lifetime of the battery, that the battery discharge current has been > 10% of nominal current rating (1C) and ≤ 20% of nominal current rating (1C).
7	32	unsigned integer (s)	Total 20-50% Discharge Time Total accumulated time over the lifetime of the battery, that the battery discharge current has been > 20% of nominal current rating (1C) and ≤ 50% of nominal current rating (1C).
8	32	unsigned integer (s)	Total 50-80% Discharge Time Total accumulated time over the lifetime of the battery, that the battery discharge current has been > 50% of nominal current rating (1C) and ≤ 80% of nominal current rating (1C).
9	32	unsigned integer (s)	Total 80-100% Discharge Time Total accumulated time over the lifetime of the battery, that the battery discharge current has been > 80% of nominal current rating (1C).
10	32	unsigned integer (s)	Cycle Count This is an estimation of the number of cycles done by the battery. A discharge of more than 10% SOC will increment the counter.

Total DischargeTime is the sum of the five (5) discharge time values.



320 - 13711 International Place, Richmond, BC, V6V 2Z8, Canada

discoverlithium.com



+ 1.604.242.0350



info@discoverlithium.com

6.7 PGN 126979 (0x01F003) – Fault Status (FaultSts)

Message Type	N2K Fast Packet
Transmission Rate	1000 ms
Default Priority	6
Version Added	1

This message is an array of tuples with the structure shown below. The message is always sent with a fixed length of 2 N2K Fast Packet frames (13 bytes) regardless of how many faults are active. If no faults or warnings are present then both the type and severity will be 0.

If a fault, warning, or lockout condition is reported in severity field of the Fault Status message then this indicates that the application must not charge or discharge the battery pack.

FIELD	FIELD LENGTH (BITS)	FIELD TYPE	FIELD DESCRIPTION
1	8	Enumeration	Fault 1 Type
2	8	Enumeration	Fault 1 Severity
3	8	Enumeration	Fault 2 Type
4	8	Enumeration	Fault 2 Severity
5	8	Enumeration	Fault 3 Type
6	8	Enumeration	Fault 3 Severity
7	8	Enumeration	Fault 4 Type
8	8	Enumeration	Fault 4 Severity
9	40	RSVD	RSVD

Table 6-1 - Fault Type

FIELD	DESCRIPTION
0	Unknown
1	Low Module Voltage
2	High Module Voltage
3	Low Block Temperature
4	High Block Temperature
5	High Discharge Current
6	High Charge Current
7	Load Qualification Failed
8	Blown Fuse
9	BMS Board Temperature
10	Low Temperature Charge Fault
11	Hardware Fault
12	Relay Fault
13	High Temperature Charge Fault



Table 6-2 - Fault Severity Enum

FIELD	DESCRIPTION
0	Normal This indicates that corresponding fault is not active.
1	Recovery This indicates that the corresponding fault is in a recovery mode and there is restricted set of conditions that the battery will be allowed to operate in. For example, low voltage recovery will trigger a fault immediately if the battery detects a discharge current. This is specific to each fault type.
2	Warning This indicates that the battery is operating outside of its specifications and will trigger a fault to open it's internal relay imminently. If this condition is detect the application must immediately stop charging or discharging the battery depending on the fault type.
3	Fault This indicates that the battery has gone into a protection mode and opened it's internal relay. The application must immediately stop attempting to charge or discharge the battery and wait for the fault to recover, depending on the fault type.

6.7.1 Note Regarding High Current Warnings and Faults

There are multiple high current faults including high discharge current, high charge current, and short circuit.

Both the high discharge current and short circuit current faults can trigger in as little as 800 us. Due to the rate at which these faults can trigger there is no warning message available for them.

System designers should design their systems so the maximum rated current of a battery or battery system is never exceeded.

6.8 PGN 126980 (0x01F004) – Shutdown Info (ShutdownInfoData)

Message Type	J1939
Transmission Rate	Asynchronous
Default Priority	5
Version Added	2

FIELD	FIELD LENGTH (BITS)	FIELD TYPE	FIELD DESCRIPTION
1	8	enum	Shutdown field indicating the reason the node is shutting down. 0 = Unknown 1 = Timeout 2 = Button Press 3 = AEBus Upgrade 4 = USB Upgrade

6.9 PGN 126981 (0x01F005) – Heartbeat

Message Type	J1939
Transmission Rate	1000 ms (when configured to transmit)
Default Priority	5
Version Added	3

FIELD	FIELD LENGTH (BITS)	FIELD TYPE	FIELD DESCRIPTION
1	8	bool	Whether the heartbeat is enabled or not.
2	56	RSVD	RSVD

6.9.1 LYNK Node

LYNK nodes can be configured to act as a heartbeat producer. When configured to be a producer, the LYNK transmits the heartbeat message every 1000 ms. The intended design is to remove power and cut communication by using a device such as an emergency-stop button. Once LYNK communication is interrupted, the heartbeat is no longer produced, and any batteries on the LYNK network shut down.

6.9.2 BMS Node

By default, a BMS node does not require a heartbeat message. Upon the first receipt of a heartbeat message, the BMS node transitions to a state where it begins to monitor for loss of the heartbeat. Once in that state, if the BMS node does not receive a heartbeat for 2500 ms, the BMS node shuts down.



6.10 PGN 126982 (0x01F006) – Battery Stats Reduced (BattStsRed)

Message Type	N2K Fast Packet
Transmission Rate	250 ms
Default Priority	6
Version Added	4

FIELD	FIELD LENGTH (BITS)	FIELD TYPE	FIELD DESCRIPTION
1	32	signed integer (mA)	Battery Current Charge current > 0 Discharge current < 0
2	8	signed integer (°C)	Battery Cell Block Temperature
3	8	signed integer (°C)	Battery Management System Temperature
4	8	unsigned integer (%)	State of Charge Valid range of 0-100%
5	8	unsigned integer (%)	State of Health Presently fixed value at 100%
6	16	unsigned integer (mV)	Max Cell Voltage (0xFFFF is Invalid)
7	16	unsigned integer (mV)	Min Cell Voltage (0xFFFF is Invalid)
8	16	unsigned integer (mV)	Average Cell Voltage (0xFFFF is Invalid)
9	32	unsigned integer (mV)	Battery Terminal Voltage (0xFFFF is Invalid)



6.11 PGN 126983 (0x01F007) – Fault Status Reduced (FaultStsRed)

Message Type	J1939
Transmission Rate	1000 ms
Default Priority	6
Version Added	4

This message is an array of tuples with the structure shown below. The message is always sent with a fixed length J1939 packet frame (8 bytes) regardless of how many faults are active. Up to 4 faults can be sent per message. If no faults or warnings are present then both the type and severity will be 0.

If a fault, warning, or lockout condition is reported in the severity field of the Fault Status message, then this indicates that the application must not charge or discharge the battery pack.

FIELD	FIELD LENGTH (BITS)	FIELD TYPE	FIELD DESCRIPTION
1	8	Enumeration	Fault 1 Type
2	8	Enumeration	Fault 1 Severity
3	8	Enumeration	Fault 2 Type
4	8	Enumeration	Fault 2 Severity
5	8	Enumeration	Fault 3 Type
6	8	Enumeration	Fault 3 Severity
7	8	Enumeration	Fault 4 Type
8	8	Enumeration	Fault 4 Severity

The fault types and severities are the same as used in “Table 6-1 - Fault Type” and “Table 6-2 - Fault Severity Enum”.

7. J1939 PGN Listings

Implementation of several ISO PGNs is required for a node wishing to actively participate on the network. For more information please see the J1939 annex and other associated J1939 standard documentation

7.1 PGN 59392 (0xE800) – ISO Acknowledgment (ISOAck)

Message Type	J1939
Transmission Rate	N/A
Default Priority	6

FIELD	FIELD LENGTH (BITS)	FIELD TYPE	FIELD DESCRIPTION
1	8	unsigned integer	Control Byte 0 = Positive Ack 1 = Negative Ack 2 = Access Denied
2	8		Group Function Value
3	24		Reserved Bits (0xFF)
4	24	PGN	PGN of Requested Information

7.2 PGN 59904 (0xEA00) – ISO Request (ISORqst)

Message Type	J1939
Transmission Rate	N/A
Default Priority	6

FIELD	FIELD LENGTH (BITS)	FIELD TYPE	FIELD DESCRIPTION
1	24	PGN	PGN of Requested Information

7.3 PGN 60928 (0xEE00) – ISO Address Claim

Message Type	J1939
Transmission Rate	1000 ms
Default Priority	6

FIELD	FIELD LENGTH (BITS)	FIELD TYPE	FIELD DESCRIPTION
1	21	unsigned integer	Unique Identifier
2	11	unsigned integer	Manufacturing Code
3	3	unsigned integer	Device Instance (lower)
4	5	unsigned integer	Device Instance (upper)
5	8	unsigned integer	Device Function
6	1	unsigned integer	RSVD
7	7	unsigned integer	Device Class
8	4	unsigned integer	System Instance
9	3	unsigned integer	Industry Group
10	1	unsigned integer	Self-Configurable Address

7.4 PGN 61588 (0x00F094) – HVES1D5

Message Type	J1939
Transmission Rate	20 ms
Default Priority	6
Version Added	1

FIELD	FIELD LENGTH (BITS)	FIELD TYPE	FIELD DESCRIPTION
1	16	unsigned integer (0.05A/bit) 1600 to 1612.75 A	Discharge current limit of the battery bank (offset by -1600A)
2	16	unsigned integer (0.05A/bit) 1600 to 1612.75 A	Charge Current Limit (offset by -1600A)
3	16	unsigned integer (0.0015625 %/bit) 0 to 100 %	Min Cell SOC
4	16	unsigned integer (0.0015625 %/bit) 0 to 100%	Max Cell SOC

The battery network master will begin sending this message when a charger (device function 141) has been identified on the network.



7.5 PGN 61600 (0x00F0A0) – HVES1D7

Message Type	J1939
Transmission Rate	100 ms
Default Priority	6
Version Added	1

Field	Field Length (bits)	Field Type	Field Description
1	24	unsigned integer (0.001 kWh/bit) 0 to 16449 kWh	Discharge Energy Capacity of the battery bank.
2	24	unsigned integer (0.001 kWh/bit) 0 to 16449 kWh	Charge Energy Capacity of the battery bank.
3	16	unsigned integer (0.05V/bit) 0 to 3212.75 V	Charge Voltage Limit

The battery network master will begin sending this message when a charger (device function 141) has been identified on the network.

7.6 PGN 64789 (0x00FD15) – BCH1

Message Type	J1939
Transmission Rate	1000 ms
Default Priority	6
Version Added	1

FIELD	FIELD LENGTH (BITS)	FIELD TYPE	FIELD DESCRIPTION
1	4	unsigned integer	Battery Chargers State: 0 – Idle 1 – Charging 2 – Stand-by 3-12 – RSVD 13 – Error related to battery state (High Temp, etc) 14 – Charger Failure 15 – Not Available
2	2	unsigned integer	State of AC Bus Connection 0 – Charger is Disconnected 1 – Charger is Connected 2 – Error 3 – Not Available
3	2		rsvd
4	16	unsigned integer (0.05 V/bit) 0 to 3212.75 V	Charger Output Voltage
5	16	unsigned integer (0.05 A/bit) -1600 to 1612.75 A	Charger Output Current



7.7 PGN 6912 (0x001B00) – HVES1C1

Message Type	J1939
Transmission Rate	As Needed
Default Priority	3
Version Added	2

FIELD	FIELD LENGTH (BITS)	FIELD TYPE	FIELD DESCRIPTION
1	2	unsigned integer	Bus Connected Command Not Implemented
2	2	unsigned integer	Power Down Command 00 = Power-down not requested 01 = Execute normal power-down 10 = Execute emergency power-down 11 = Don't care/Take no action
3	2	unsigned integer	Active Isolation Test Command Not Implemented
4	2	unsigned integer	Passive Isolation Test Command Not Implemented
5	2	unsigned integer	Cell Balance Command Not Implemented
6	2	unsigned integer	Enable Internal Charger Command Not Implemented
7	2	unsigned integer	Operation Consent Command Not Implemented
8	2	unsigned integer	High Side Resistor Connect Command Not Implemented
9	2	unsigned integer	Low Side Resistor Connect Command Not Implemented
10	46	unsigned integer	Unused

This command may be used to cause the BMS to open its relay and power off. There is no difference in the handling of normal and emergency power downs.



7.8 PGN 61705 (0x00F109) – HVESSTS1

Message Type	J1939
Transmission Rate	As Needed
Default Priority	6
Version Added	3

FIELD	FIELD LENGTH (BITS)	FIELD TYPE	FIELD DESCRIPTION
1	16	unsigned integer	SLI input power Not Implemented
2	16	unsigned integer	Hi Voltage Power Not Implemented
3	8	unsigned integer	Compressor speed Not Implemented
4	8	unsigned integer	Relative Not Implemented
5	2	unsigned integer	Heater Status 0 - Heater Off 1 - Heater On 3 - Undefined
6	2	unsigned integer	HVIL Status Not Implemented
7	4	unsigned integer	Mode Not Implemented
8	2	unsigned integer	Coolant Level Not Implemented
9	6	unsigned integer	Unused

This command is only used to get the heater status. It only returns whether it is on or off.

7.9 PGN 64538 (0x00FC1A) – HVESSTC1

Message Type	J1939
Transmission Rate	As Needed
Default Priority	6
Version Added	3

FIELD	FIELD LENGTH (BITS)	FIELD TYPE	FIELD DESCRIPTION
1	8	unsigned integer	Inlet Coolant Not Implemented
2	8	unsigned integer	Outer Coolant Not Implemented
3	16	unsigned integer	Coolant Flow Not Implemented
4	2	unsigned integer	Heater Enable 0 - Manual Heater Off 1 - Manual Heater On 2 - Auto Note that any external messages only support heater on and heater off. External messages do not support the setting to return to 2 - Auto heater.
5	2	unsigned integer	Coolant Pump Not Implemented
6	2	unsigned integer	Compressor Status Not Implemented
7	2	unsigned integer	Unused

